

A1
A-1

MAIN COUNTER SECTION

3/4" = 1'-0"

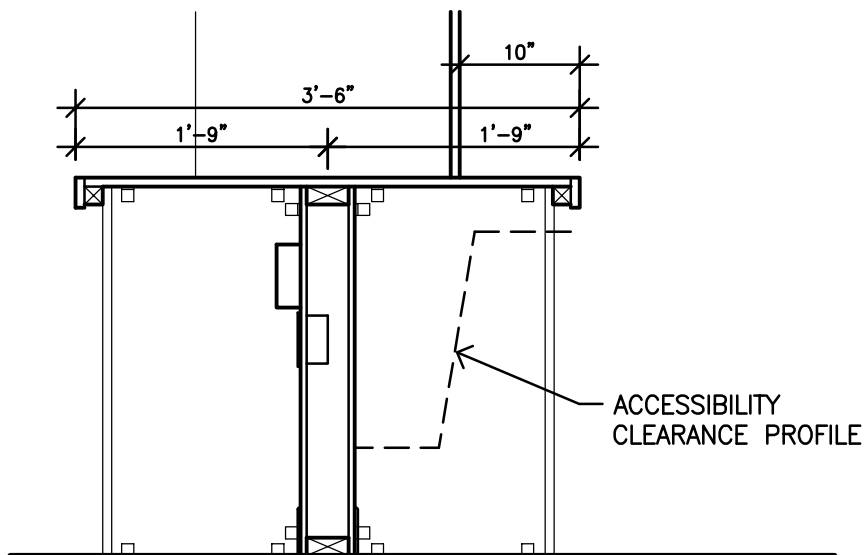

**REFER TO A1/A-1 FOR NOTES

B1
A-1

LOW COUNTER SECTION

3/4" = 1'-0"

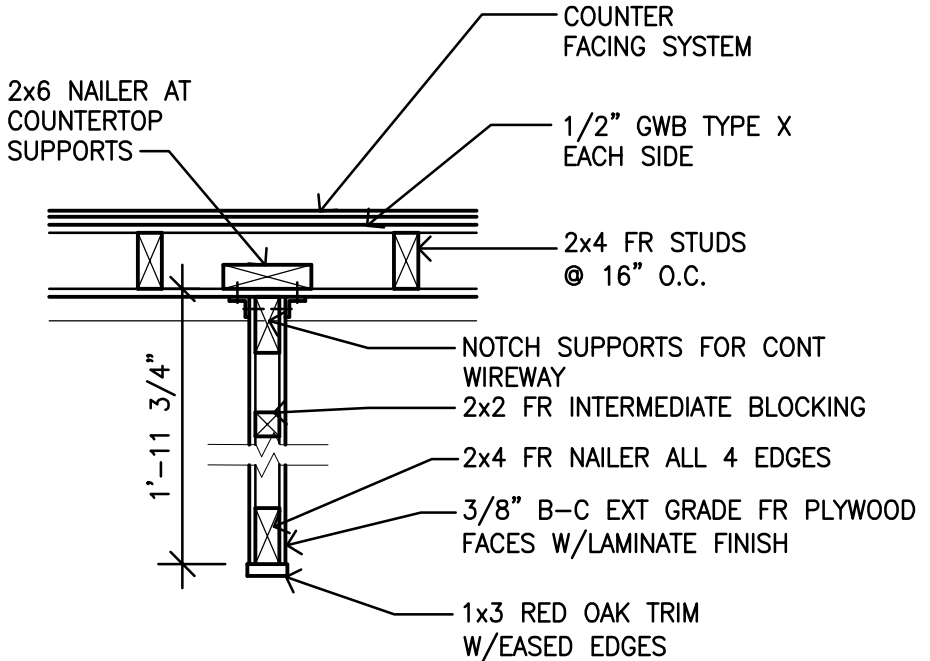

C1
A-1

SUPPORT PLAN DETAIL

1" = 1'-0"