

B3 OVERHEAD DOOR HEAD DET
A2.B3 1 1/2" = 1'-0"

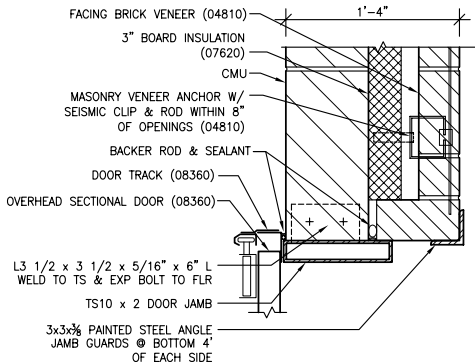

C3 OVERHEAD DOOR JAMB DET
A2.B3 1 1/2" = 1'-0"